



HACETTEPE UNIVERSITY
FOOD RESEARCH CENTRE



COMPUTER VISION BASED IMAGE ANALYSIS FOR RAPID DETECTION OF ACRYLAMIDE IN HEATED FOODS

Vural Gökmen

Director of Food Research Center
Department of Food Engineering
Hacettepe University
Ankara, Turkey

vgokmen@hacettepe.edu.tr

2nd International **MoniQA** Conference

8-10 June 2010, Krakow, Poland

„Emerging and persisting food hazards:
Analytical challenges and socio-economic impact”

ACRYLAMIDE* FOOD

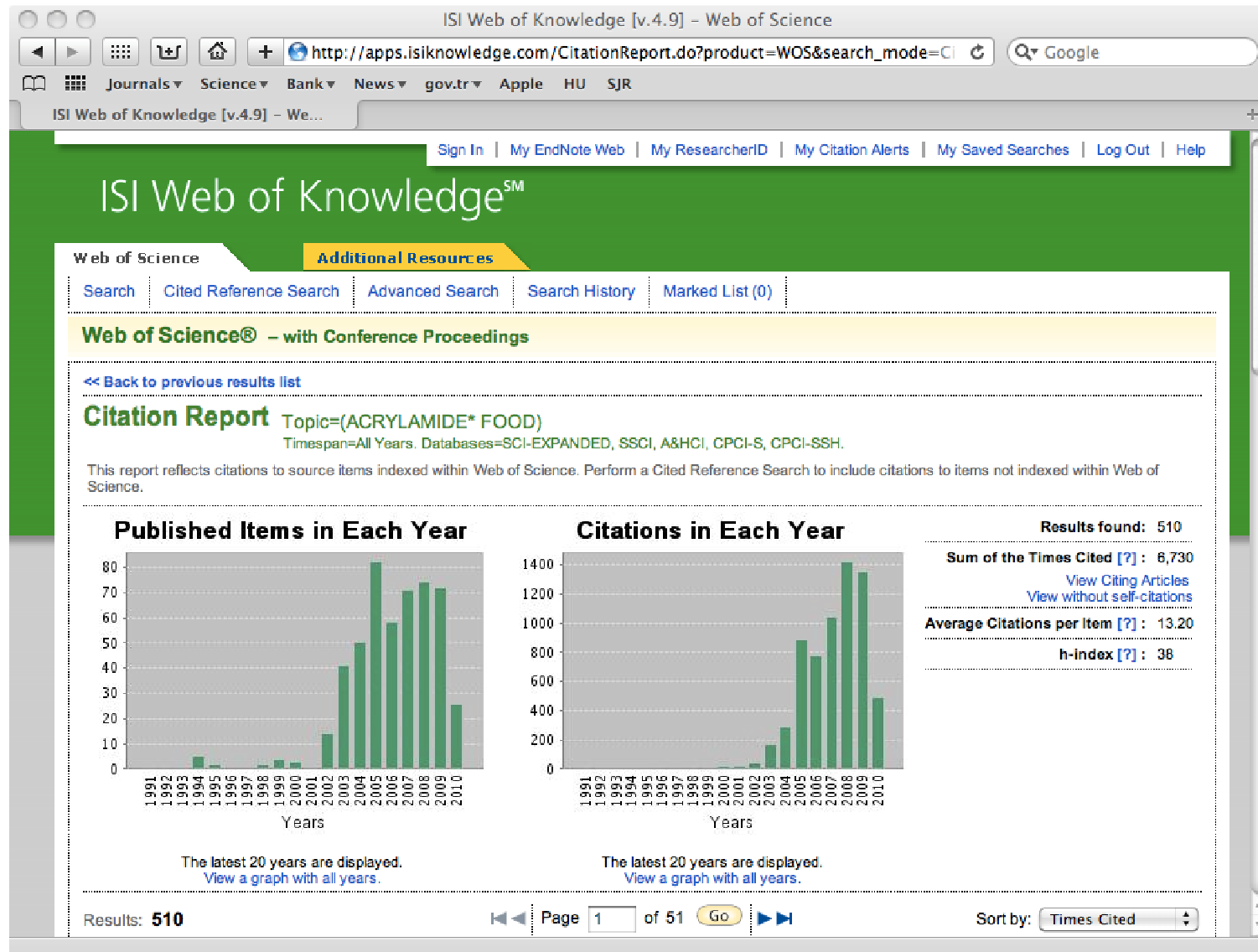

What we learnt so far?

- Mechanism of its formation
- Factors affecting
- Possible mitigation strategies
- Next Step ?

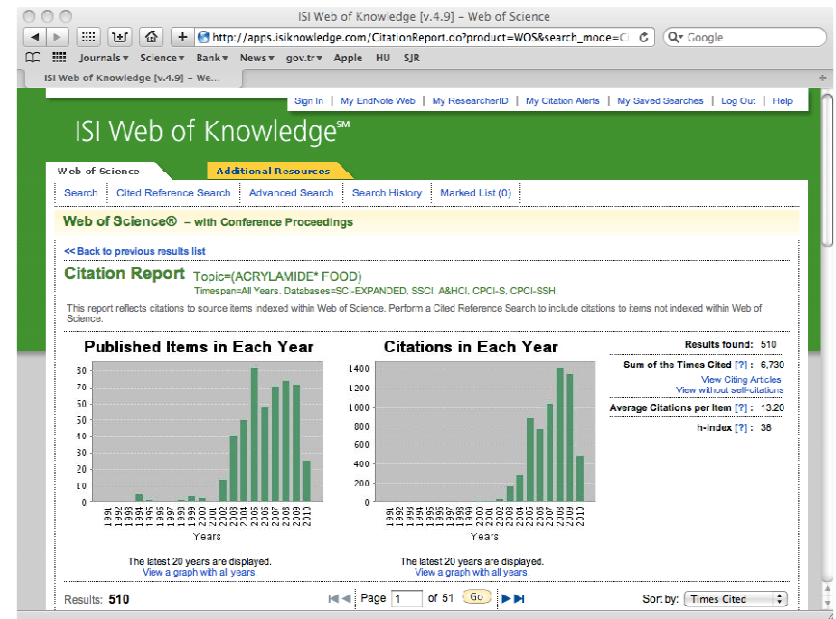

Difference in these chips **OBVIOUS** !



~50 $\mu\text{g}/\text{kg}$

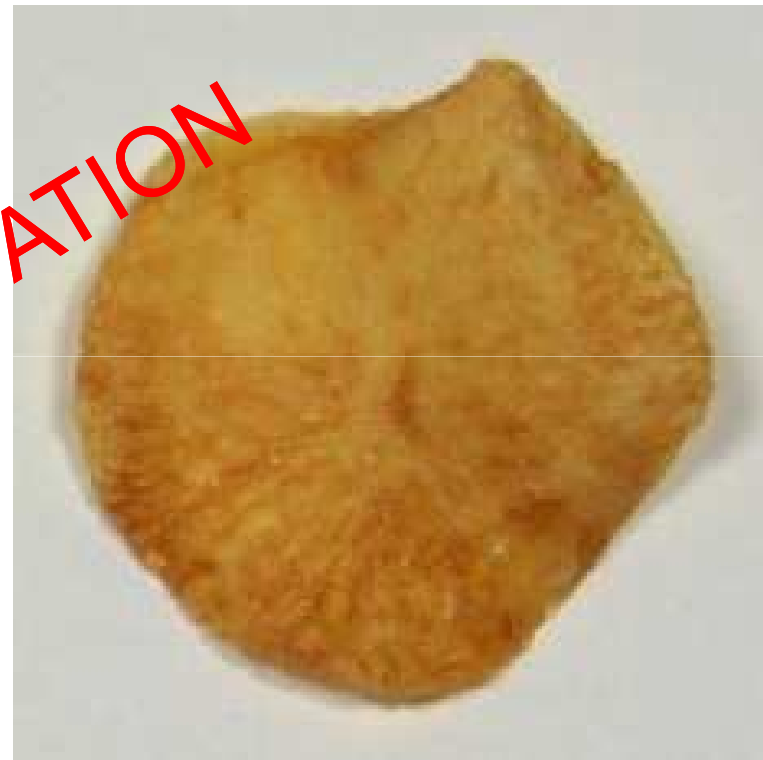

~2800 $\mu\text{g}/\text{kg}$

Acrylamide is visible !

Aim

- We aimed to develop a computer vision based image analysis technique to predict acrylamide level in fried potatoes and bakery products.

A Fact : Browning and acrylamide formation take place simultaneously during heating!

Q: Can we relate them? How?



Acrylamide & Color (Browning)

Acrylamide

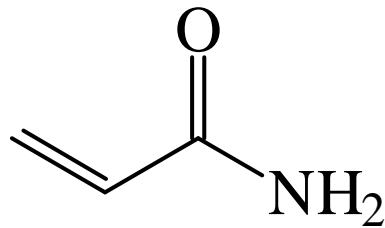

Brown

Acrylamide in Foods

- Possible human carcinogen, first detected in 2002 in heated foods. Forms in foods high in asparagine if heated at $>100^{\circ}\text{C}$ as a result of Maillard reaction.
 - Fried foods
 - Baked foods
 - Roasted foods

LC Maillard (1912)

Maillard Reaction

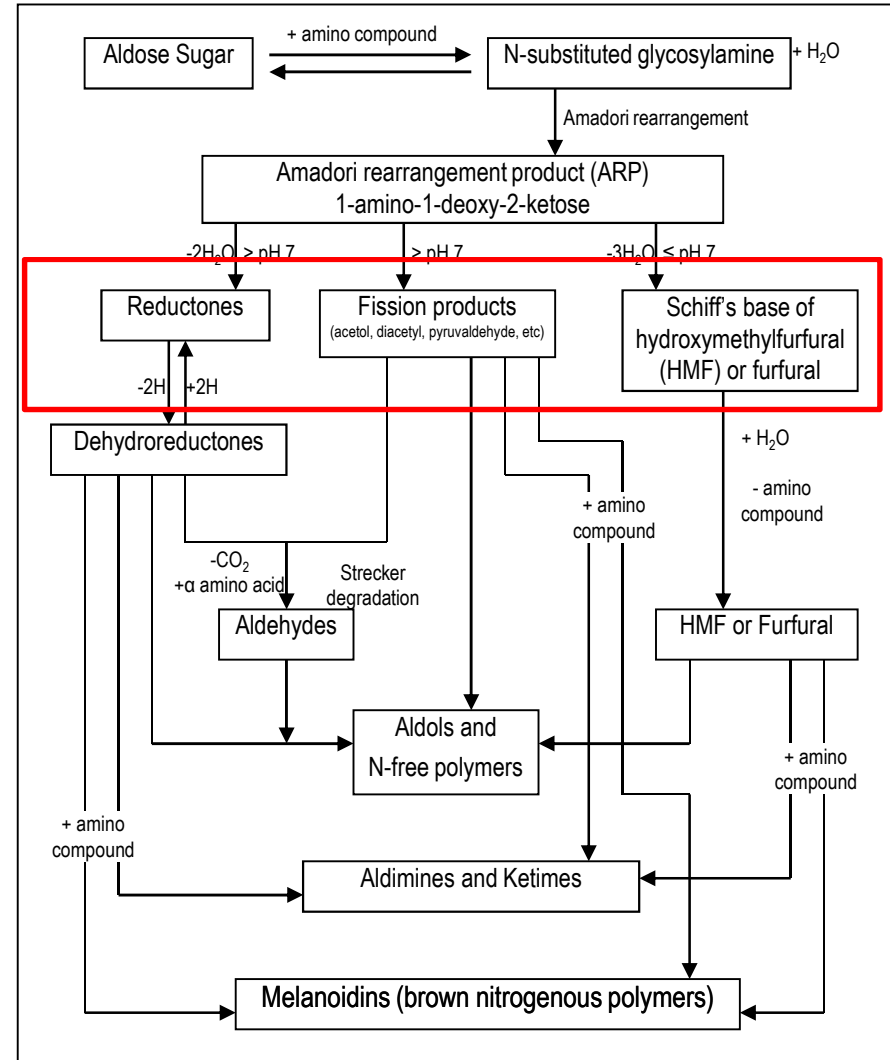
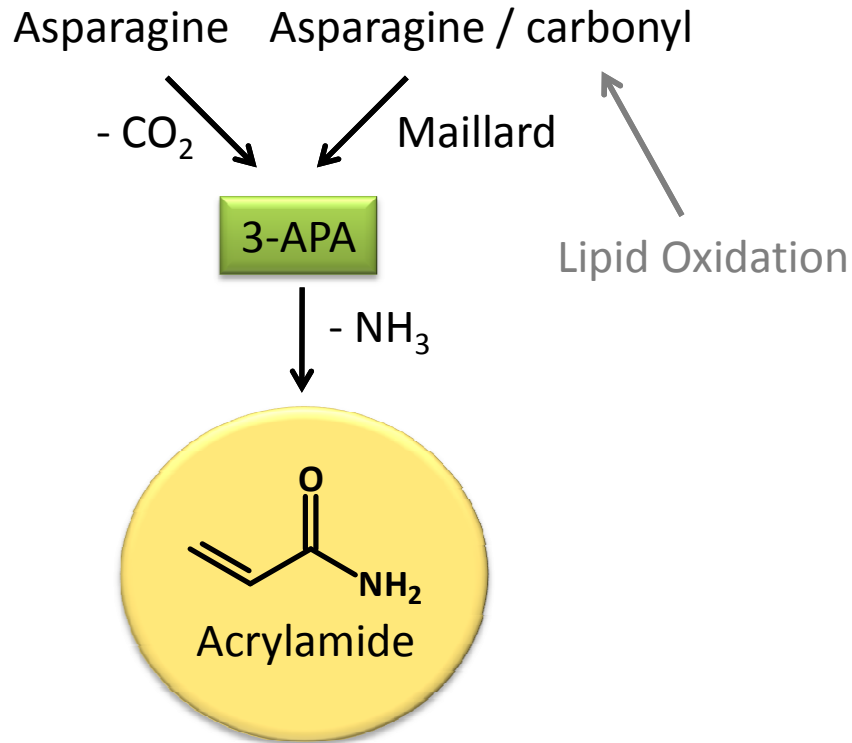

There is a chemical mechanistic basis to relate acrylamide with browning !

Factors Affecting Acrylamide Formation in Foods



Agronomic

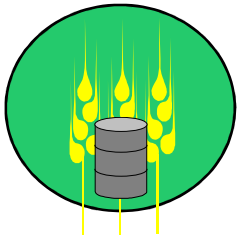

Recipe



Process

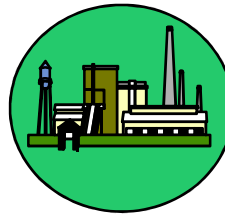

Final Preparation

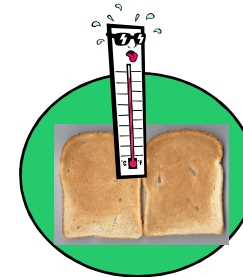

Acrylamide Toolbox

Same factors affect also browning !

Browning in Foods

- Thermal processing of foods at extreme temperatures results in surface browning as a result of Maillard reaction.

- Fried foods
- Baked foods
- Roasted foods



images of ...
browned foods

Understanding a digital image

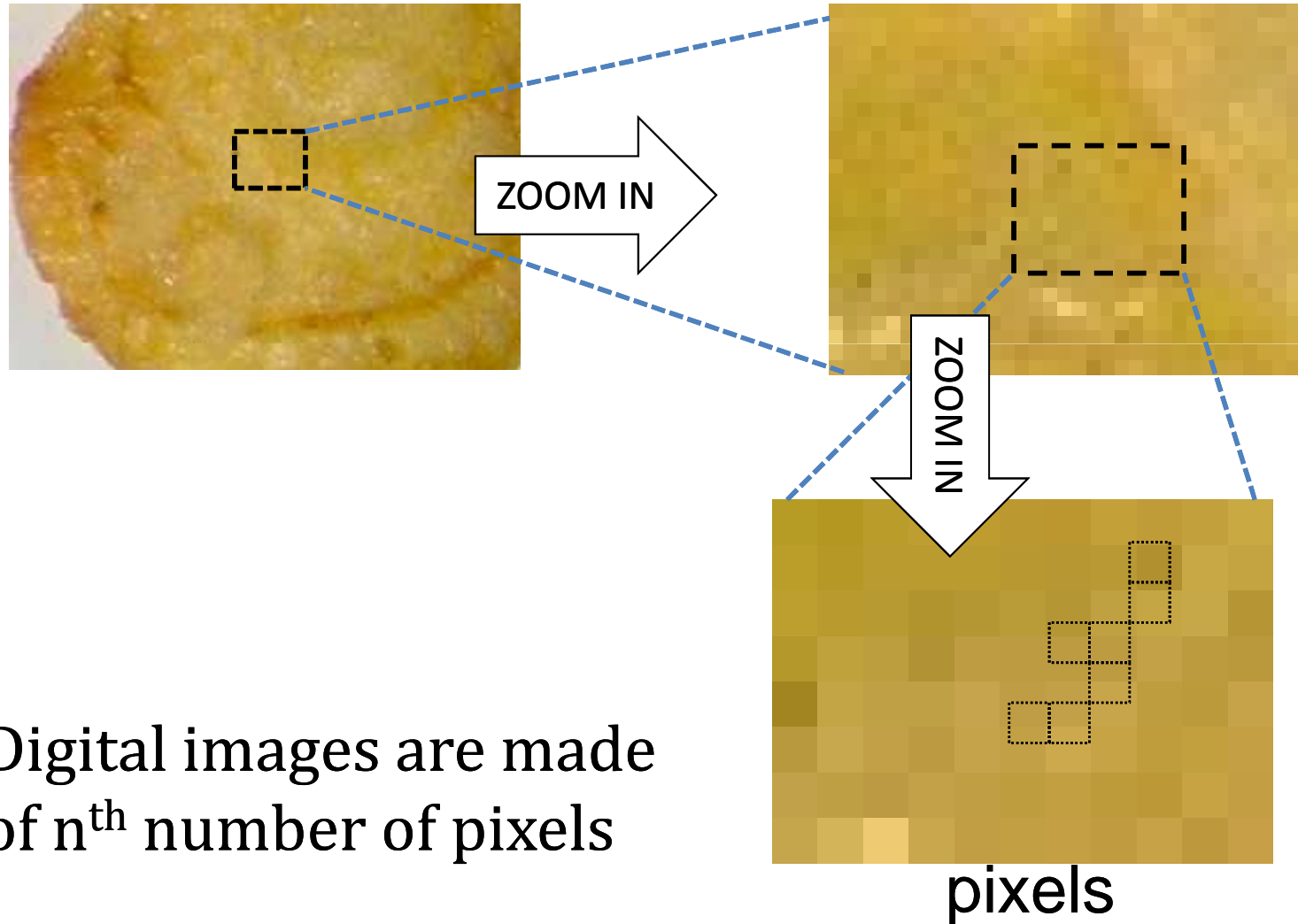

Digital images are made
of n^{th} number of pixels

Pixel

- A typical image captured by a digital camera consists of an **array of vectors** called pixels.
- Each pixel has **red**, **green** and **blue** color values :

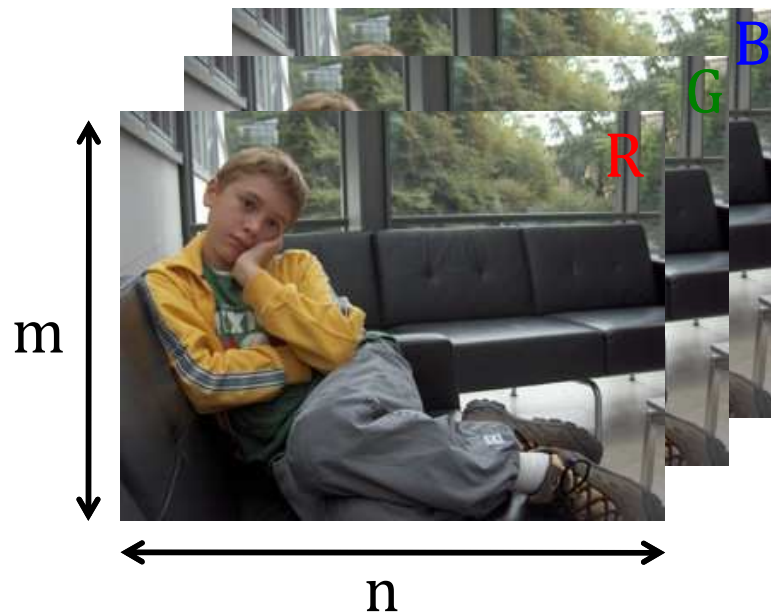

$$\Rightarrow x[n, m] = \begin{bmatrix} x_r(n, m) \\ x_g(n, m) \\ x_b(n, m) \end{bmatrix}$$

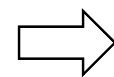

form a matrix in size of **n x m**

Image Data (*image.jpg*)

The picture is read between **0 – 255**
pixel-by-pixel as '*RGB*' space.

An 1024 x 768 image

786,432 pixels (data points)

2,359,296 numbers (RGB values)

```
Z(:, :, 3) = BLUE
           Columns 1 through 17
           228  215  206  204  202  203  204  204
           226  213  204  202  200  199  200  199
Z(:, :, 2) = GREEN
           0  201  200
           1  202  201
           8  199  198
           Columns 1 through 17
           232  219  210  208  206  207  208  208
           230  217  208  206  204  203  204  203
Z(:, :, 1) = RED
           205  204
           206  205
           203  202
           Columns 1 through 17
           227  214  205  203  201  202  203  203
           225  212  203  201  199  198  199  198
           221  209  201  200  199  199  200  199
           224  212  203  202  200  200  201  200
           230  216  205  201  198  197  198  197
```

*1 megapixel means one million pixels !

Color Difference (ΔE)

The **difference** is the straight line **distance** between two color points in color space !

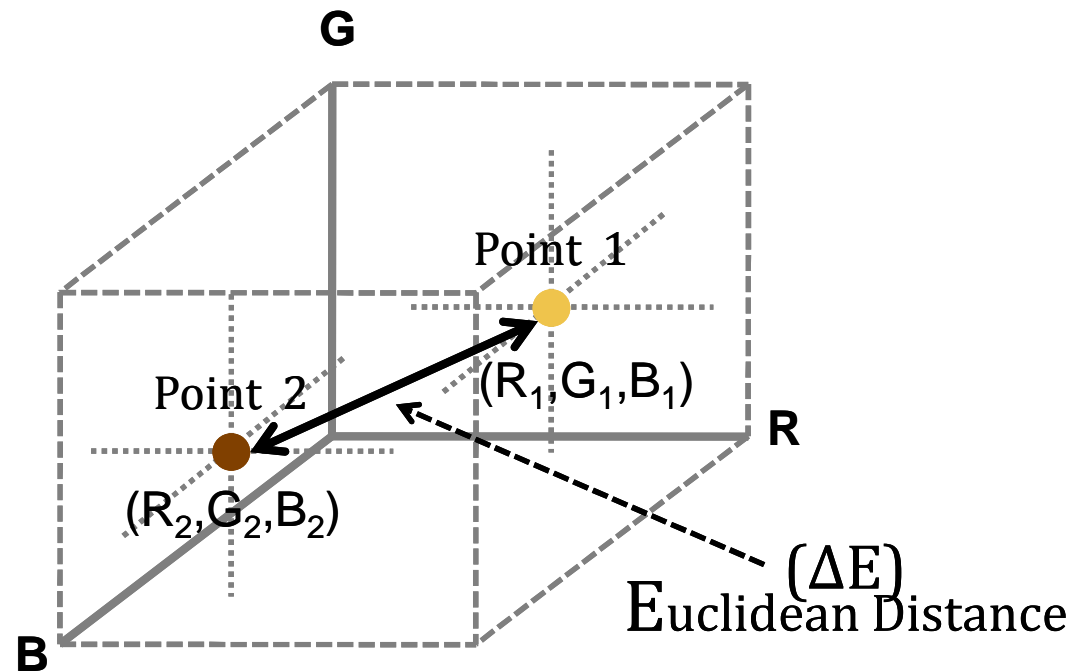

$$\Delta E = \sqrt{(R_2 - R_1)^2 + (G_2 - G_1)^2 + (B_2 - B_1)^2}$$

Measure Browning !

*Do you know **any device** available in the market which measures **browning**?*

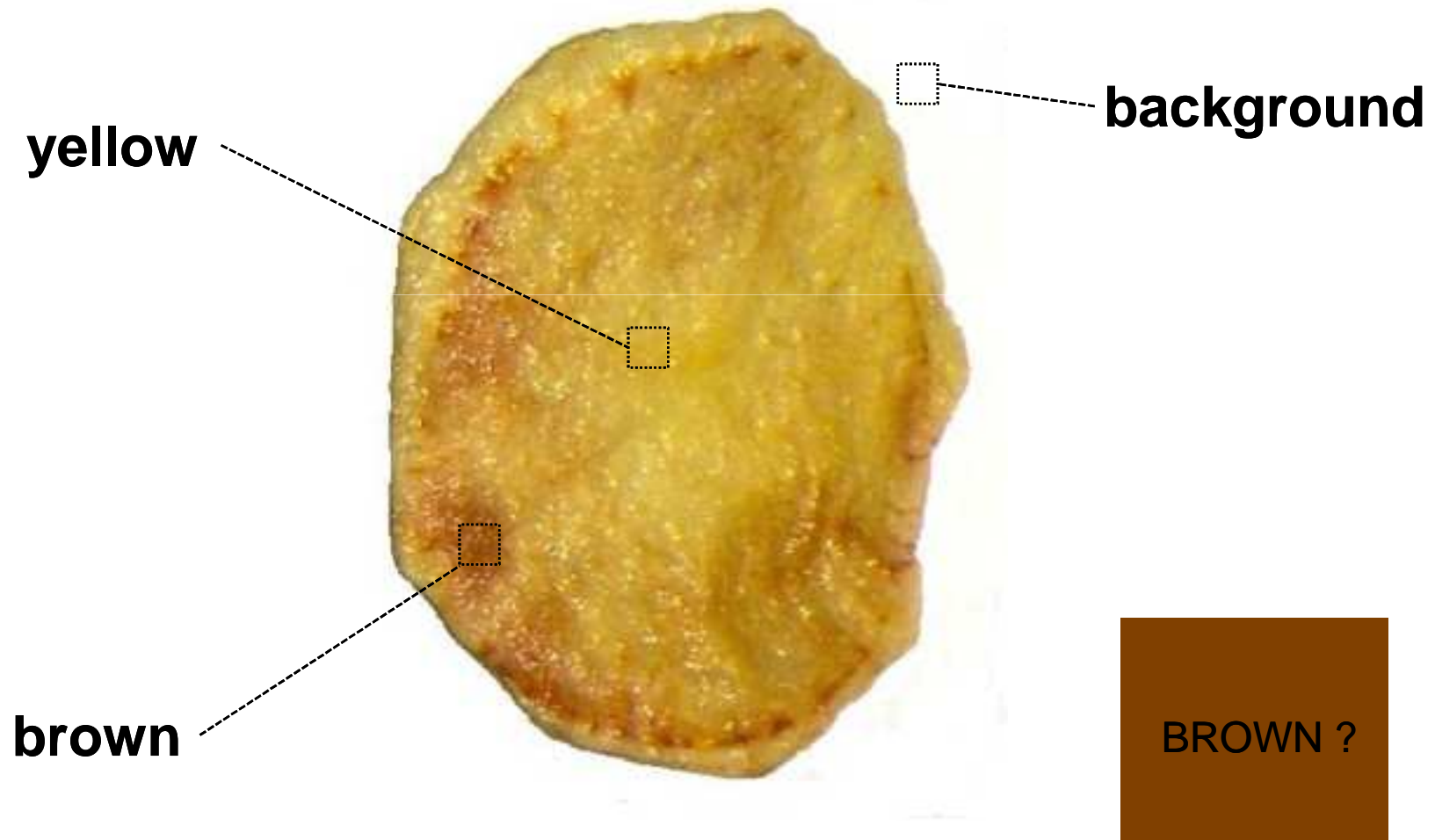

Browning Ratio

$$\text{Browning Ratio} = \frac{\text{n of brown pixels}}{\text{n of total pixels}}$$

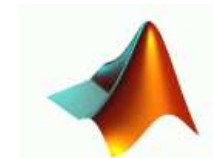

How to Procedure (Algorithm)

- Determine **mean reference** values
- **Classify (segment) pixels** according to their distance (*Euclidian*) to the mean reference values
- **Count pixels** in each groups (except background!)
- **Compute** browning ratio



Mean references for potato crisp



			Background (white)
R	0.8330	0.5870	1.0000
G	0.6940	0.3080	1.0000
B	0.1530	0.0540	1.0000

We have 3 references (yellow, brown, background)

Segmentation Process

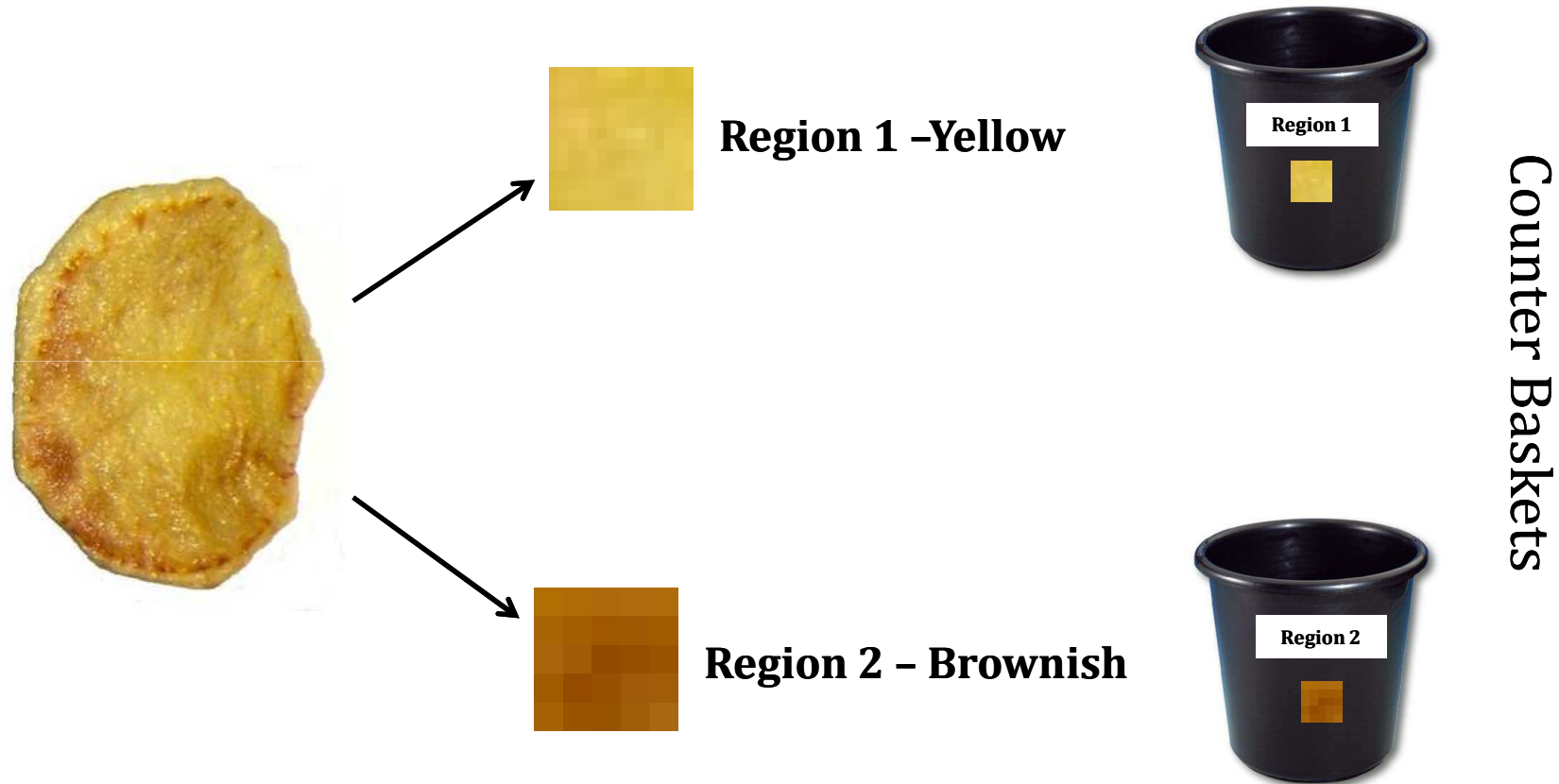

*Segmentation is based on calculated **Euclidian distances** (ΔE), if the pixel is closer to yellow or brown, it is assigned or classified accordingly!*

Algorithm in Practice

- Capture the IMAGE
- Run the algorithm to segment the image
- Compute the browning ratio from the segmented image
- Calculate the level of acrylamide from the matrix-matched calibration

Matrix represents a specific food formulation or product !

Image acquisition

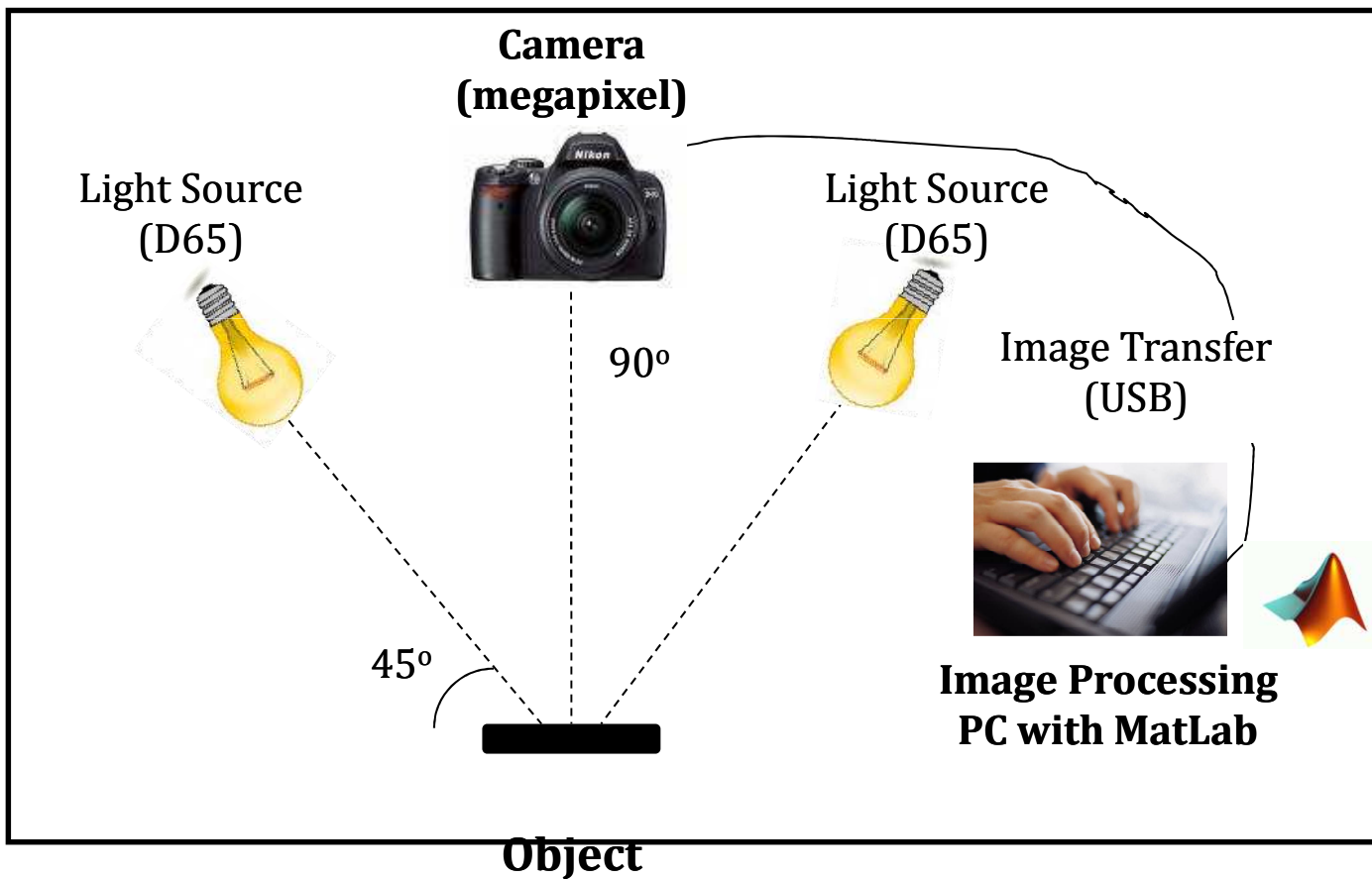

Original vs Segmented

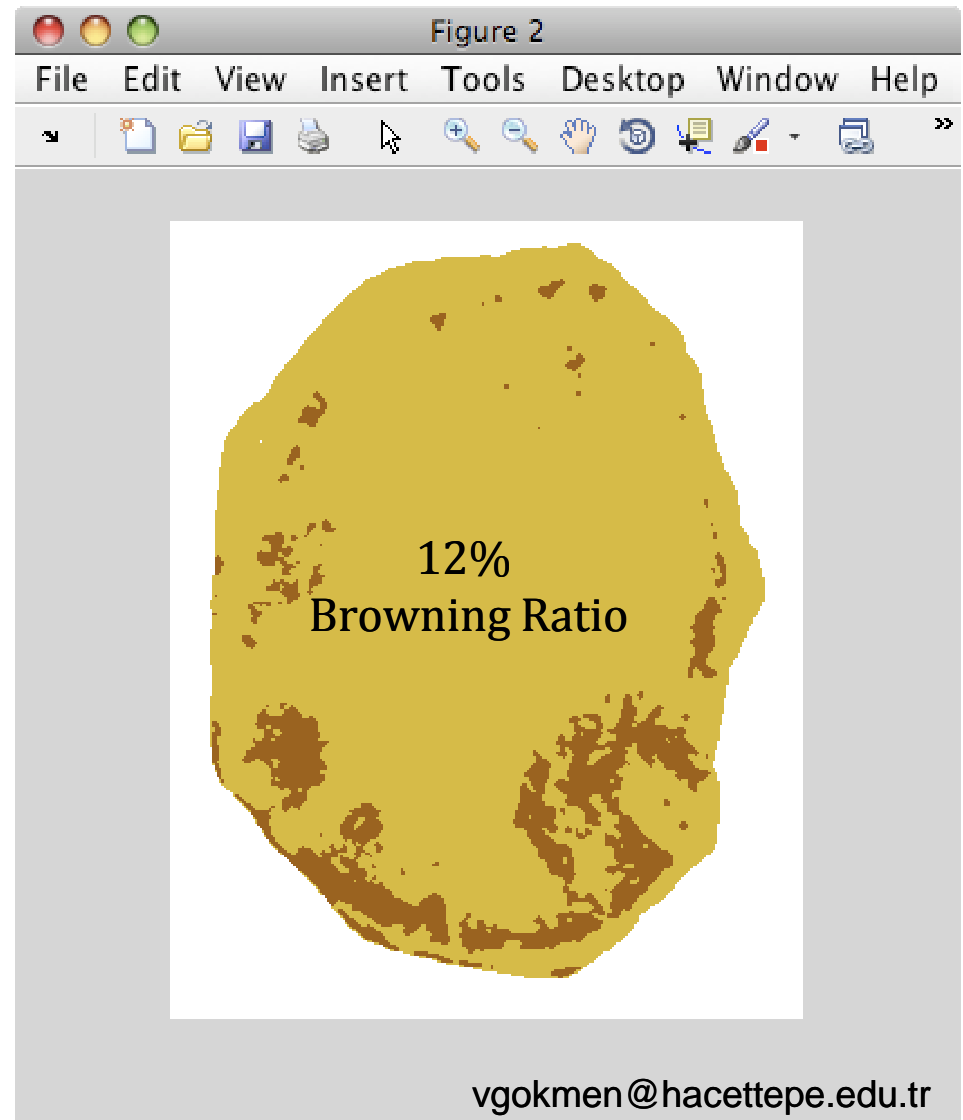
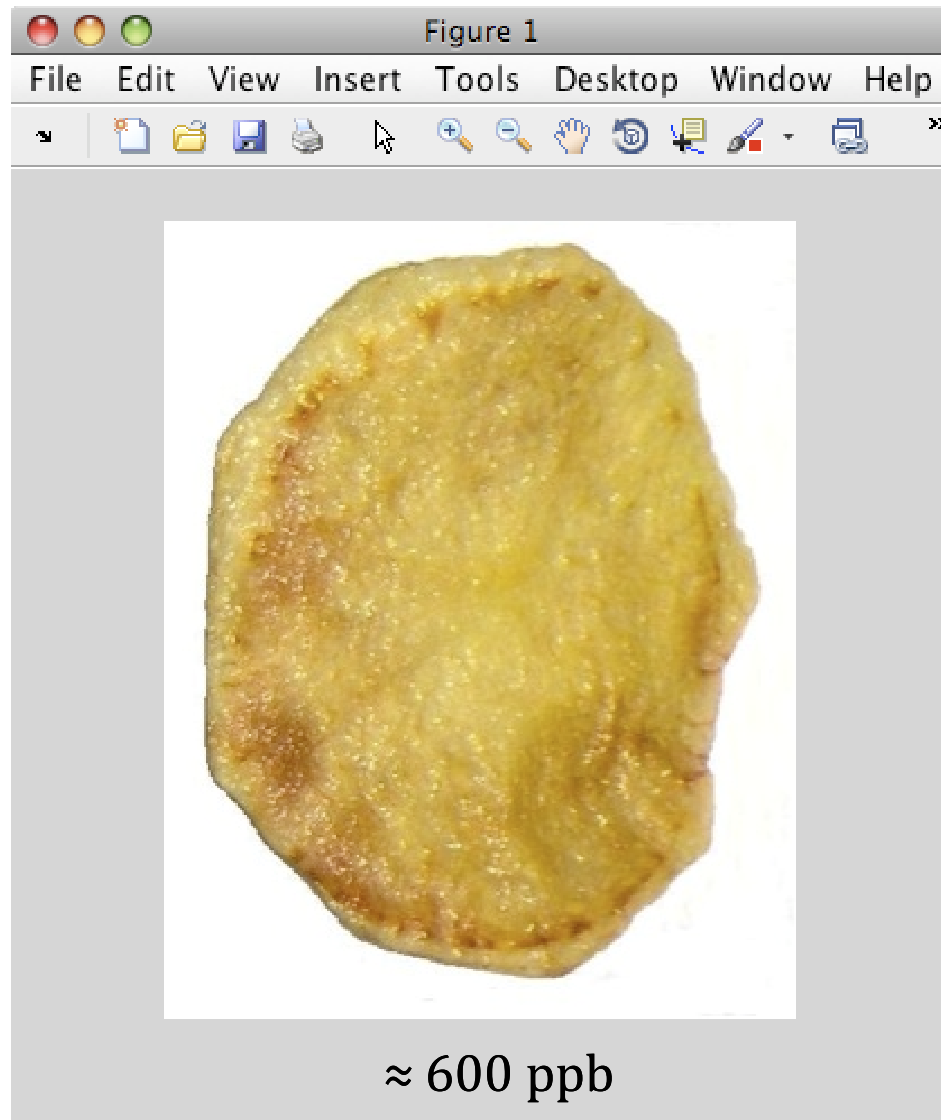

Case Study

- Case 1: Potato crisps
- Case 2: Cookies

Potato Crisps

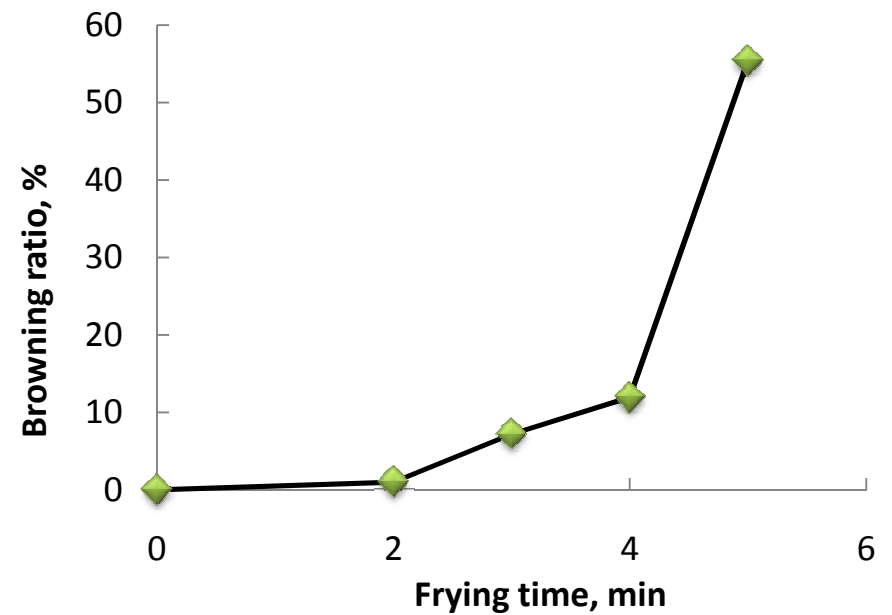
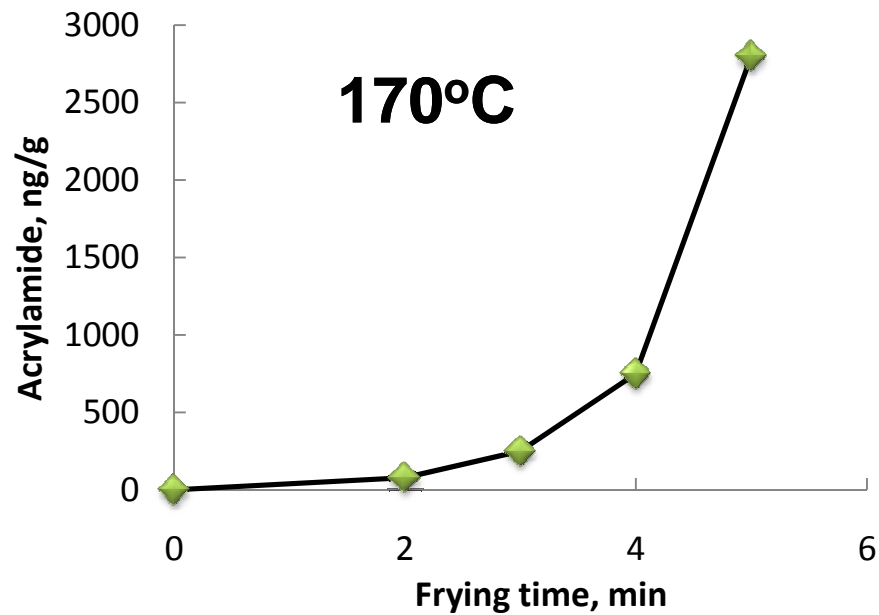



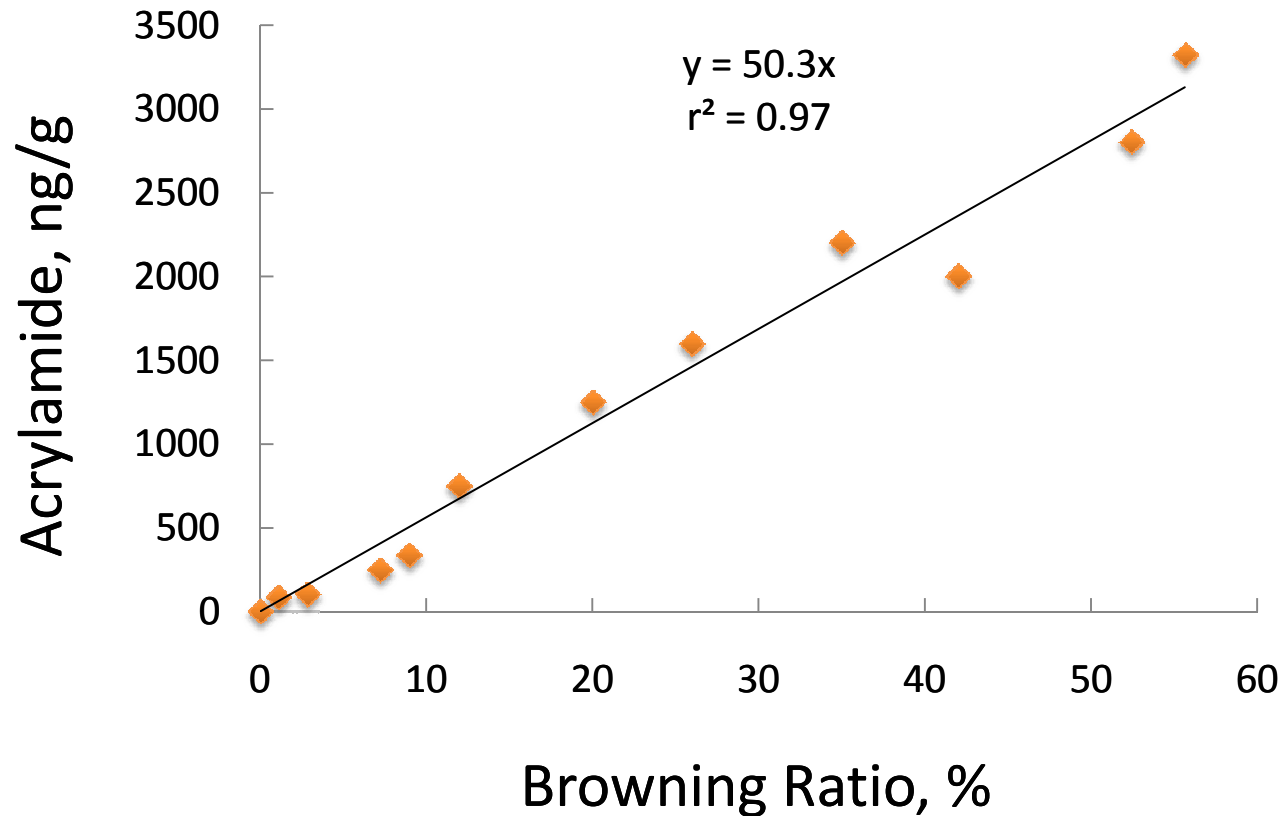

Browning and acrylamide formation have similar kinetic trends during frying of potato crisps !

Browning ratio relates to Acrylamide concentration in potato crisps

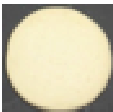
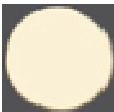
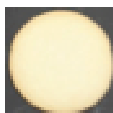
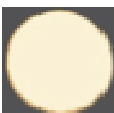
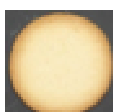

Kind of MATRIX-MATCHED calibration

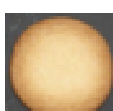
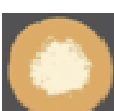
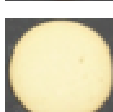
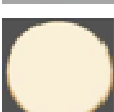
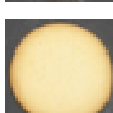
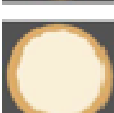
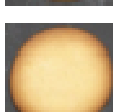
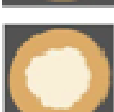
Baking Cookies

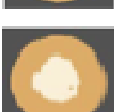
Baking Condition	Cookie Image		Browning Ratio, %
	Original	Segmented	
200-C × 10 min			2.54
200-C × 15 min			6.83
200-C × 20 min			37.93
200-C × 25 min			71.63
220-C × 10 min			6.33
220-C × 15 min			30.70
220-C × 20 min			60.31
220-C × 25 min			76.35

Baking Cookies

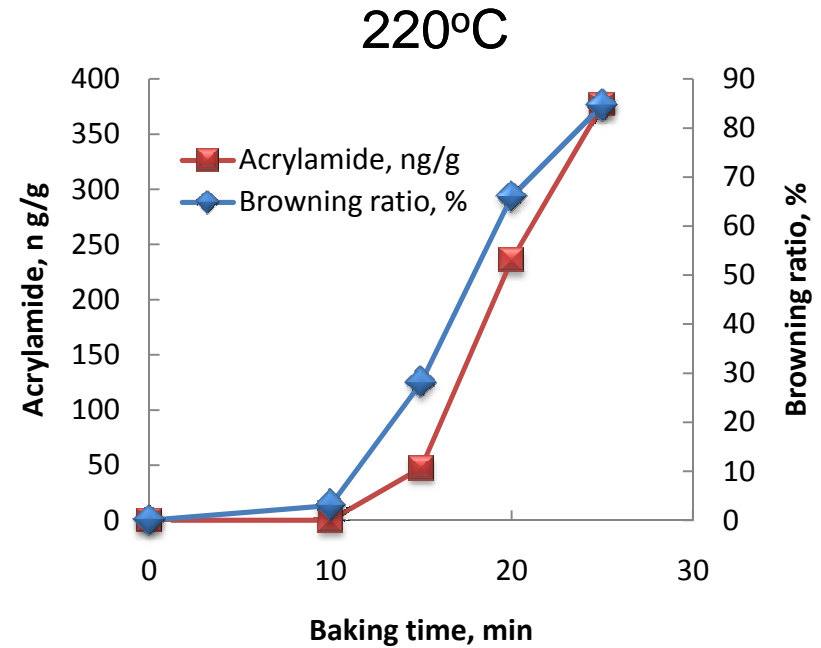
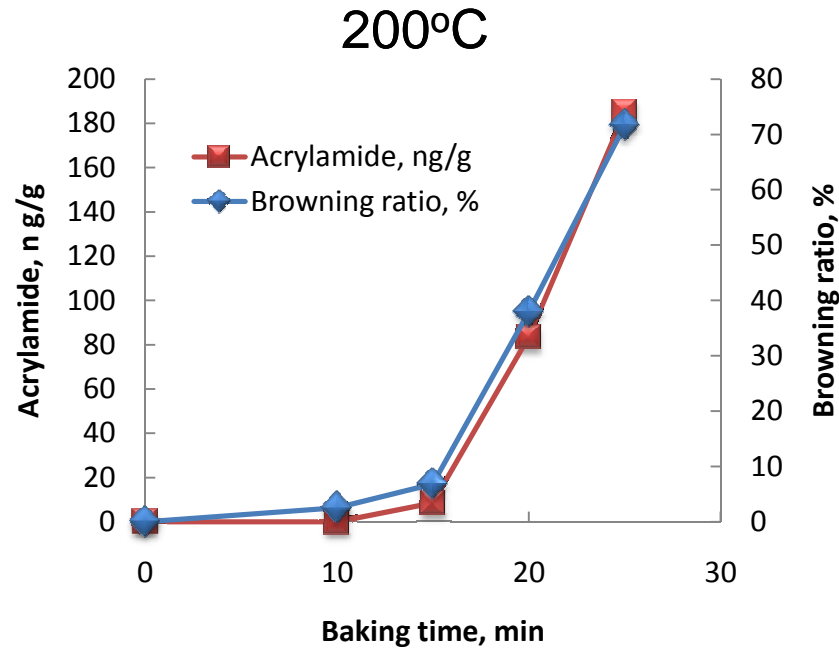

Browning and acrylamide formation have similar kinetic trends during baking !

Browning ratio relates to Acrylamide concentration in cookies

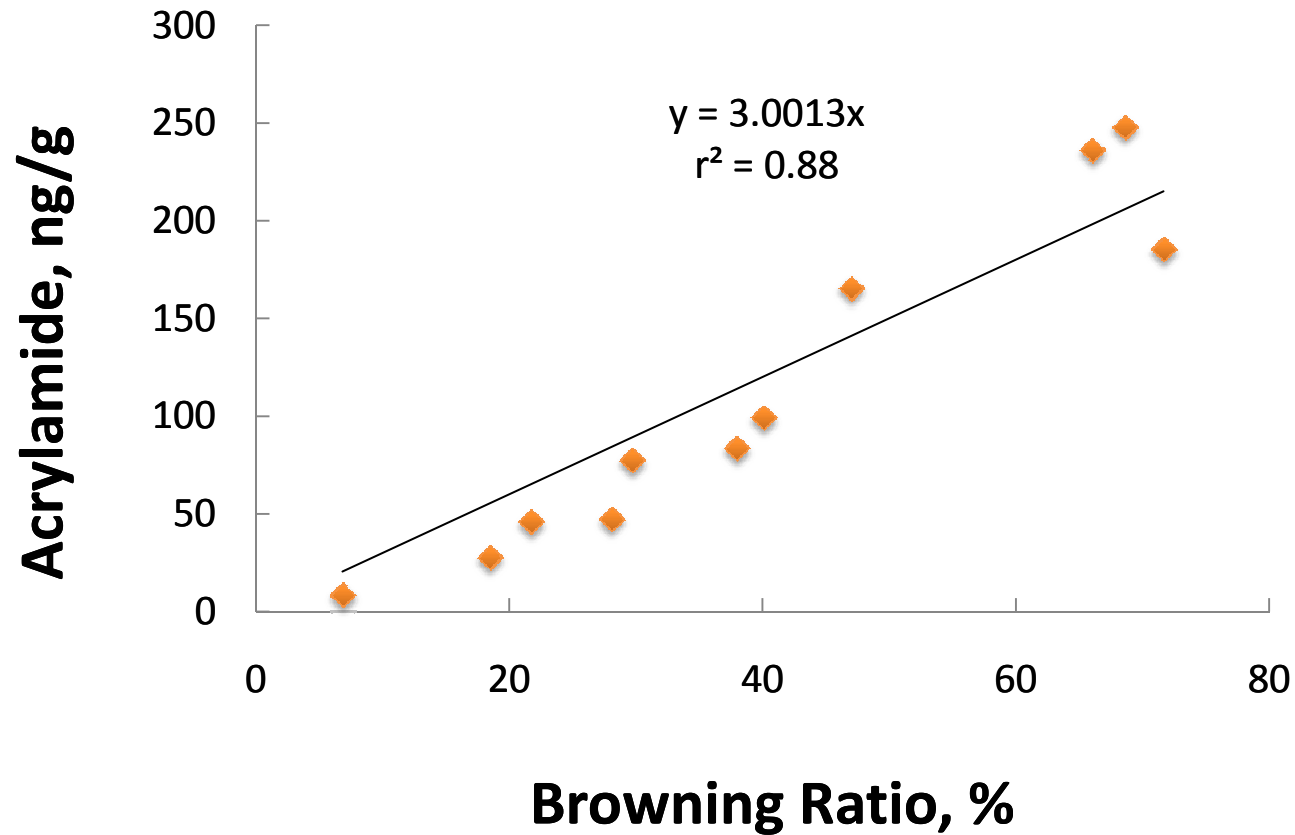

Automatic Inspection

We can monitor food processes using computer vision based matrix-matched calibration

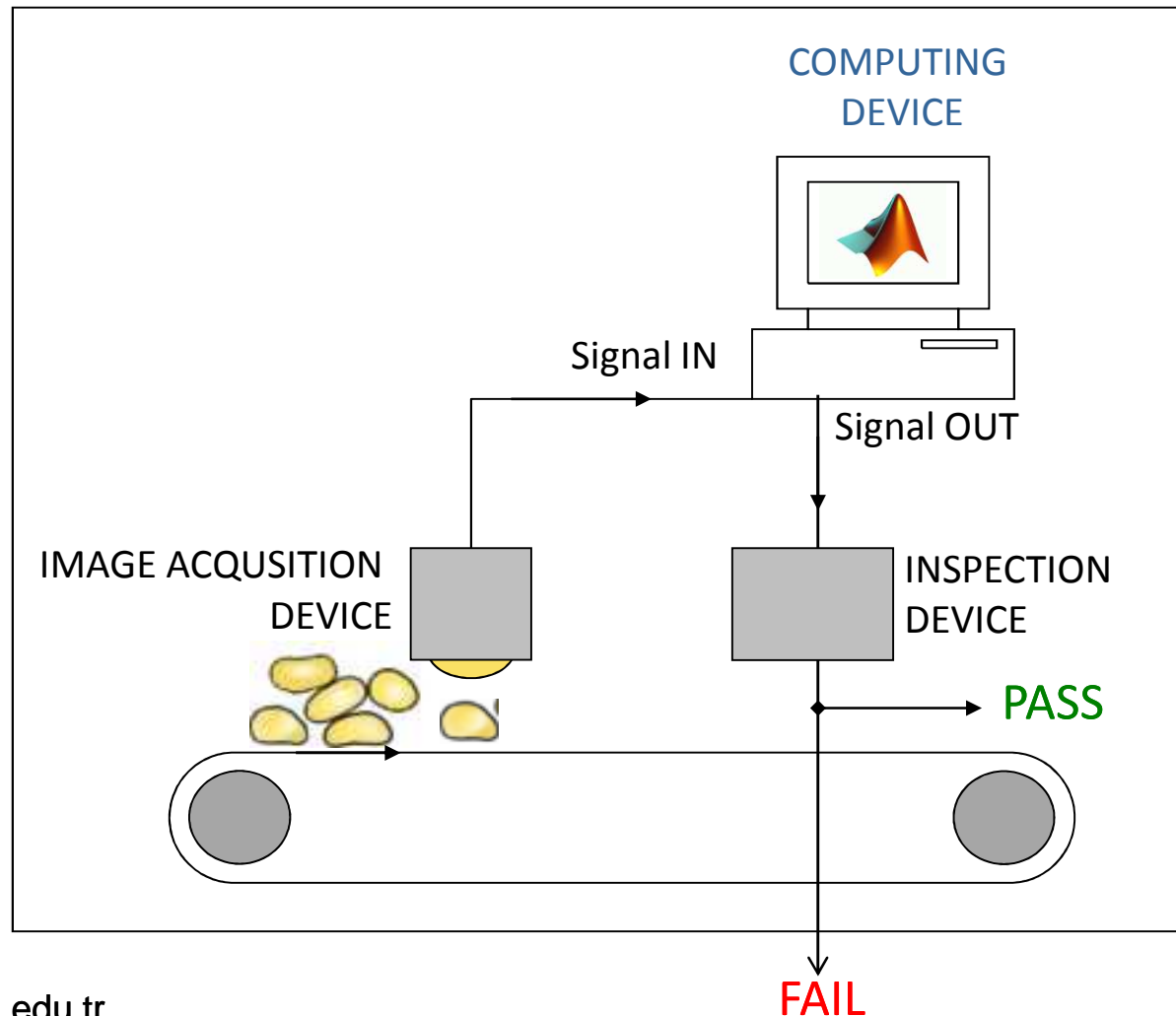

We always measure color!

See
Touch
Smell
Taste
Hear



We have a pair of device !
(Even Homer Simpson ...)

To Conclude

The color (to see) is the **first sensation** that a consumer perceives and uses as a **tool** to **accept** or **reject**.

Because, the color observation allows the detection of **quality** and certain **anomalies** or defects of a product.

As exemplified for potato crisps and cookies, frying and baking process can be monitored online for browning development, so to predict acrylamide formation.

